

INSTALLATION OPERATION MANUAL

ASG series

- ▶ ASG - 3.6SL - ZH
- ▶ ASG - 4SL - ZH
- ▶ ASG - 4.6SL - ZH
- ▶ ASG - 5SL - ZH
- ▶ ASG - 6SL - ZH

CONTENT

PREFACE

Summary	1
Applicable Products	1
Applicable Staff	1
Symbol Definition	1

1 OPEN THE CARTON TO CHECK

1.1 Inspection before acceptance	2
1.2 Packing list	2
1.3 storage	3

2 SAFETY PRECAUTIONS

2.1 General safety	4
2.2 PV string safety	4
2.3 Inverter Safety	5
2.4 Battery Safety	6
2.5 Personnel requirements	6

3 INTRODUCTION

3.1 Products Introduction	7
3.2 Exterior Introduction	7
3.3 Dimension	8
3.4 Display Description	8

PREFACE

4 APPLICATION

4.1 Application-Scenario	10
4.2 Application mode	12
4.3 Function characteristics	15

5 INSTALLATION

5.1 Installation Requirements	16
5.2 Installation of inverter	19
5.3 Electrical connection	20

6 EQUIPMENT COMMISSIONING AND MAINTENANCE

6.1 Check before power-on	32
6.2 Power on the equipment	33
6.3 Set inverter parameters via App	33
6.4 Power off the equipment	33
6.5 Equipment removal	34
6.6 Equipment scrapping	34
6.7 Fault Handling	34
6.8 Regular maintenance	39

7 TECHNICAL PARAMETER

40

Summary

This document mainly introduces the installation, electrical connection, adjustment, maintenance and troubleshooting methods of ASG series single-phase hybrid inverter. Before installing and using the inverter, please read this manual carefully to understand the safety information and get familiar with the functions and characteristics of the inverter. The document may be updated from time to time. Please obtain the latest version of the information and other product information from the official website.

Applicable products

This document is applicable to the following 5 types of AUX ASG series single-phase hybrid inverter:
ASG-3.6SL-ZH / ASG-4SL-ZH / ASG-4.6SL-ZH / ASG-5SL-ZH / ASG-6SL-ZH

Applicable staff

It is only applicable to professionals who are familiar with local regulations and standards and electrical system, have received professional training and are familiar with the relevant knowledge of the product.

Symbol definition

To better use this manual, the following symbols are used to highlight important information. Please read the symbols and instructions carefully.



Danger:

Indicates a highly potential danger that, if not avoided, could result in death or serious injury to personnel.



Warning:

Indicates a moderate potential hazard, which could lead to death or serious injury if not avoided.



Watch out:

Indicates a low level of potential danger that, if not avoided, may result in moderate or mild injury to personnel.



Watch out:

Emphasizing and supplementing the content may also provide tips or tricks for optimizing product usage, which can help you solve a problem or save you time.

1 OPEN THE CARTON TO CHECK

1.1 Inspection before acceptance

Before signing for the product, please carefully check the following contents:

- Check the outer packaging for any damage, such as deformation, holes, cracks, or other signs that may cause damage to the equipment inside the packaging. If there is any damage, do not open the packaging and contact your dealer.
- Check if the inverter model is correct. If there is any discrepancy, do not open the packaging and contact your dealer.
- Check whether the type and quantity of delivered items are correct, and whether there is any damage to the appearance. If there is any damage, please contact your dealer.

1.2 Packing list



Watch out:

- The number of PV DC input terminals matches the number of inverter DC input terminals.
- The datalogger and electricity meter kit are provided as optional, please refer to the actual situation.

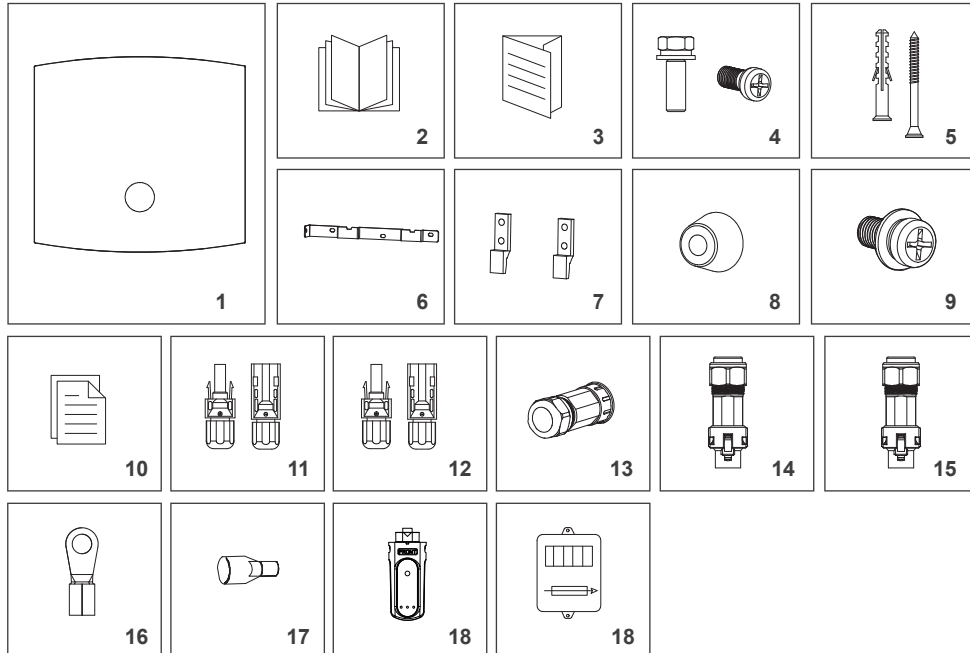

No.	Description	Model	Unit	QTY	Remark
1	Inverter	ASG-3.6~6SL-ZH	pc	1	
2	User's manual	ASG-3.6~6SL-ZH	pc	1	
3	Quick Installation Manual	ASG-3.6~6SL-ZH	pc	1	
4	Combination Screw	M5×12	pc	5	
5	Self tapping screw+bolt expansion	M6*50+Φ10*45	set	3	
6	Wall-mounting bracket	ASG-3.6~6SL-ZH	pc	1	
7	Hangers	ASG-3.6~6SL-ZH	pc	2	
8	Rubber	30*20*25	pc	1	black
9	Rubber screw	M4×12	pc	1	
10	Inspection report	ASG-3.6~6SL-ZH	pc	1	
11	PV terminal block (+, -)		pair	2	black
12	Battery terminals (+, -)		pair	1	blue
13	Signal waterproof terminal cap		set	3	black
14	Grid wiring connector		set	1	black
15	Load wiring connector		set	1	blue
16	Grounding OT terminal		pc	1	
17	AC wiring terminal		pc	6	
18	Datalogger		pc	1	optional
19	Meter Kit		set	1	optional

1.3 storage

If the inverter is not put into use immediately, please store it according to the following requirements:

- Make sure that the outer packing box is not removed and desiccant in the box is not lost.
- Make sure that the storage temperature is always -40°C~+70°C and the storage relative humidity is always 0~95% without condensation.
- Make sure the inverter stacking height and direction are placed according to the label on the packing box.
- Make sure there is no risk of toppling the inverter after stacking.
- Regular inspection is required during storage. If the package is damaged due to insect and rat bite, the packaging materials shall be replaced in time.
- The inverter shall be put into use after being stored for a long time and inspected and confirmed by professionals.

2 SAFETY PRECAUTIONS

The safety precautions contained in this document must always be observed when operating the equipment.



Watch out:

The inverter has been designed and tested in strict accordance with safety regulations, but as electrical equipment, the relevant safety instructions must be observed before any operation on the equipment. Improper operation may lead to serious injury or property damage.

2.1 General safety



Watch out:

- Due to product version upgrading or other reasons, the document content will be updated from time to time. If there is no special agreement, the document content cannot replace the safety precautions in the product label. All descriptions in this document are for guidance only.
- Please read this document carefully for products and precautions before installing the equipment.
- Professional and qualified electrical technicians who shall be familiar with the relevant standards and safety specifications of the project site must carry out all equipment operations.
- Insulation tools and personal protective equipment shall be used to ensure personal safety during inverter operation. Electrostatic gloves, wrist strap and antistatic clothing shall be worn when contacting with electronic devices to protect the inverter from electrostatic damage.
- Equipment damage or personal injury caused by inverter not installed, used or configured in accordance with the requirements of this document or corresponding user manual is not within the responsibility scope of equipment manufacturer.

2.2 PV string safety



Danger:

- Please use the DC wiring terminal provided with the box to connect the inverter DC cable. If other types of DC wiring terminals are used, serious consequences may be caused, and the equipment damage caused thereby is not within the scope of the equipment manufacturer.
- The solar array (solar panel) will have DC high voltage.



Warning:

- PV modules used with inverters must have IEC 61730 class A rating or other equivalent standard class.
- Make sure good grounding of component frame and support system.
- Do not ground the PV array positive (+) or negative (-) as this may cause serious damage to the inverter.
- Make sure that the DC cables are firmly connected without looseness after connection.
- Use a multimeter to measure the positive and negative electrodes of the DC cable. Make sure that the positive and negative electrodes are correct, no reverse connection occurs and the voltage is within the allowable range.
- Do not connect the same PV string to multiple inverters, or the inverter may be damaged. In order to reduce the risk of fire, the inverter connected circuit requires an overcurrent protection device (OCPD). DC OCPD shall be installed according to local requirements. All PV power supplies and circuit conductors shall have disconnect connections in accordance with NEC Article 690, Part II.

2.3 Inverter Safety



Danger:









- Please connect the inverter AC cable with the AC wiring terminal provided with the box. If other types of DC wiring terminals are used, serious consequences may be caused, and the equipment damage caused thereby is not within the scope of the equipment manufacturer.
- Danger of electric shock. There are no serviceable parts inside the machine. Please do not disassemble it. Please obtain service from qualified and recognized service technicians.



Warning:

- Make sure that the voltage and frequency of the grid connection access point meet the inverter grid connection specifications.
- It is recommended to add circuit breaker or fuse and other protective devices at the AC side of the inverter, and the specification of the protective device shall be 1.25 times greater than the maximum AC output current of the inverter.
- The protective ground wire of inverter must be firmly connected to make sure that the impedance between zero line and ground wire is less than 10 Ω .
- Copper core cable is recommended for AC output line, and aluminum wire is prohibited.
- If the PV system is not equipped with batteries, do not use the off-grid load function. The system power consumption risk caused by this will exceed the warranty scope of the equipment manufacturer.
- It is forbidden to connect the power grid to the off-grid output terminal.

Identifications on inverter box are as follows:

 <p>There is high voltage after the inverter is powered on. Trained professional electrical technicians must perform all inverter operations. There is large contact current after the inverter is powered on. Before the inverter is powered on, it must be ensured that the inverter has been well grounded</p>	 <p>Residual voltage still exists after the inverter is powered off, and it takes 5 minutes to discharge to the safe voltage.</p>
 <p>Please read the product manual carefully before operating the equipment.</p>	 <p>Potential hazards after equipment operation. Please take protective measures during operation.</p>
 <p>When the inverter is working, the enclosure temperature is high and there is a danger of scalding. Do not touch it.</p>	 <p>Connection point of protective earthing wire.</p>
 <p>CE symbol</p>	 <p>The equipment shall not be treated as domestic garbage. Please treat the equipment according to local laws and regulations or send it back to the equipment manufacturer.</p>

2.4 Battery Safety

Warning:

- The inverter manufacturer must approve the battery used in conjunction with the inverter, and the approved battery list can be obtained through the official website or consulted with local distributors.
- Before installing the device, please carefully read the user manual corresponding to the battery to understand the product and precautions. Please strictly follow the requirements of the battery user manual.
- If the battery has been fully discharged, please strictly follow the corresponding battery user manual to charge the battery.
- The battery current may be affected by some factors, such as temperature, humidity, weather conditions, etc., which may lead to battery current limiting and affect charging and discharging performance.
- If the battery cannot start, please contact the after-sales service center as soon as possible. Otherwise, the battery may be permanently damaged.
- Use a multimeter to measure the positive and negative poles of the DC cable, ensuring that the positive and negative poles are correct; and the voltage is within the allowable range.
- Do not connect the same battery pack to multiple inverters, as this may cause damage to the inverters.



2.5 Personnel requirements

Watch out:

- Personnel responsible for installing and maintaining equipment must first undergo strict training, understand various safety precautions, and master the correct operating methods.
- Only qualified professionals or trained personnel are allowed to install, operate, maintain, or replace equipment or components.

3 INTRODUCTION

3.1 Products Introduction

The AUX ASG series single-phase hybrid inverter integrates an energy management system in the PV system, controls and optimizes energy flow, and can adapt to the requirements of the smart grid. The load, stored in the battery, and output to the grid, uses the electricity generated in the PV system.

3.2 Exterior Introduction

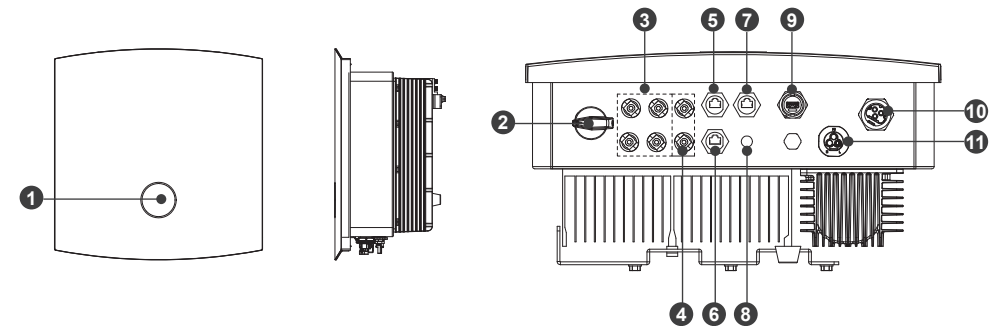

No.	Items	Description
1	LED screen	Indicates the working status of the inverter
2	DC switch	Control DC input on or off (warning: this switch does not have breaking capacity and is prohibited to operate when the machine is running)
3	PV DC port	Connect PV module with PV wiring connector
4	Battery DC port	Connect the battery with the battery connector
5	DRM port	Demand response interface (note: applicable to Australian regulations, optional)
6	BMS communication port	The battery BMS communication line can be connected via CAN or RS485
7	Meter communication port	Smart meters can be connected via RS485
8	Cold start switch	When the off-grid mode is powered by battery alone, activate the machine. First, turn on the battery breaker and activate the battery. Then press this button for 5 seconds. The panel lamp will be on after waiting for a moment. At this time, the machine can be started and set
9	Communication module port	The communication module can be connected via RS485, supporting optional communication modules such as bluetooth, Wi-Fi and 4G
10	Utility/national grid power interface (black)	Connect AC Utility/national grid supply
11	Load interface (blue)	Connecting AC load

3.3 Dimension

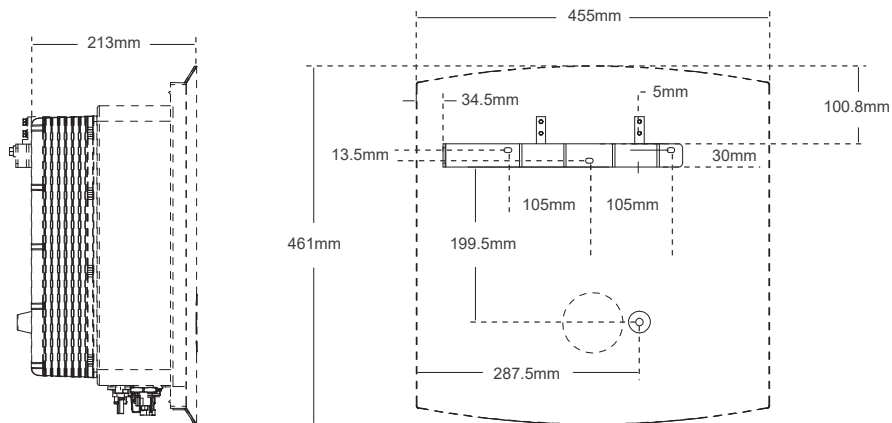

Model	Weight	Size
ASG - 3.6L - ZH	19kg	461mm × 455mm × 213mm
ASG - 4SL - ZH	19kg	461mm × 455mm × 213mm
ASG - 4.6SL - ZH	19kg	461mm × 455mm × 213mm
ASG - 5SL - ZH	19kg	461mm × 455mm × 213mm
ASG - 6SL - ZH	19kg	461mm × 455mm × 213mm

3.4 Display Description

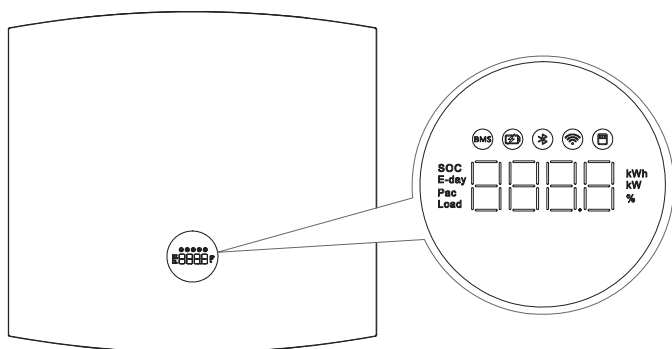

Indicator diagram	Status	Description
BMS diagram	Off	BMS No communication
	Flashing	There is battery voltage, but BMS communication is abnormal
	Always on	BMS establishes communication
Battery diagram	Off	Battery not connected (battery voltage not detected)
	Flashing	Battery connected but voltage below cutoff voltage
	Always on	Battery connection is normal
Bluetooth diagram	Off	Bluetooth not connected
	Always on	Bluetooth connected
WiFi	Off	Communication module port has no communication
	Always on	Communication module port is normal
Electricity meter diagram	Off	No communication established with the meter
	Flashing	Turn on the meter's anti-reverse current function, but the meter's communication is abnormal
	Always on	Establish communication with the electricity meter
SOC	Light on	At this point, the central digital area displays the battery SOC
E-day	Light on	At this point, the central digital area displays the daily PV power generation
Pac	Light on	Currently, the central digital area displays the current day's PV power generation (When selling electricity, the digital area will display a "-" symbol)
Load	Light on	Currently, the central digital area displays real-time off grid load power
Light strip	Red light always on	Fault mode (corresponding fault code displayed in the central digital area)
	Yellow light flashes	There are over temperature and overload alarms
	Yellow light always on	standby mode
	Green light always on	Normal operation, battery not discharge
	Green light flashes	Normal operation, battery discharge

4 APPLICATION

4.1 Application Scenario

Warning:

- PV systems are not suitable for connecting devices that rely on stable power supply, such as life-sustaining medical equipment. Please ensure that the power outage of the system does not cause personal injury.
- Please try to avoid using loads with high starting currents in PV systems, such as high-power water pumps, as this may result in off grid output failure due to excessive instantaneous power.
- If the photovoltaic system is not equipped with batteries, do not use the off grid load function, as the resulting system power consumption risk will exceed the warranty range of the equipment manufacturer.
- The battery current may be affected by some factors, such as temperature, humidity, weather conditions, etc., which may lead to battery current limiting and affect the carrying capacity.
- The inverter has UPS function, and the switching time is less than 10ms. Please ensure that the off grid load capacity is less than the rated power of the inverter, otherwise it may cause the UPS function to fail to start when the power grid is powered off.
- When the inverter is protected for a single time, it can automatically restart; If it occurs multiple times, the inverter will stop and wait, and the inverter can be immediately restarted through the app.
- When the inverter is in off grid mode, it can be used normally by ordinary household loads, such as
 - Inductive load: 1-pit non-variable frequency air conditioner
 - Capacitive load: total power $\leq 0.6 \times$ inverter rated output power.

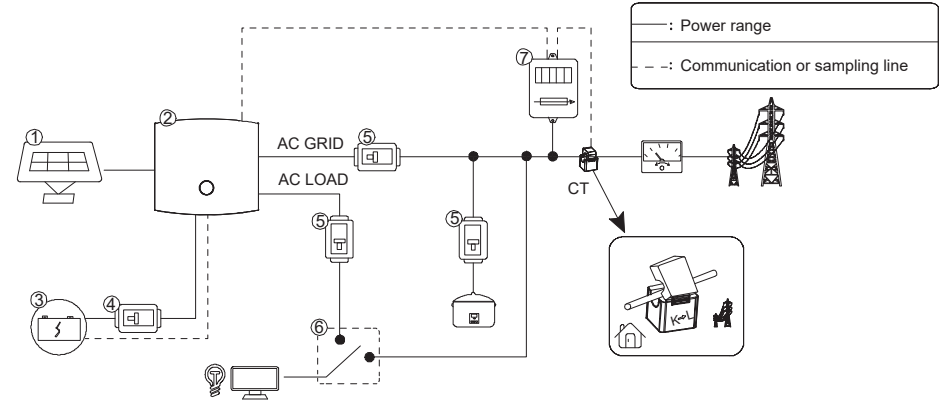

No.	Component	Description
1	PV string assembly	PV string consists of PV modules connected in series
2	Inverter	ASG Series Hybrid Inverter
3	Battery	Select according to the hybrid inverter and battery matching list
4	Battery circuit breaker	For inverter and battery protection and battery disconnection during maintenance
5	AC circuit breaker	Used for inverter and load protection and for interrupting AC supply during maintenance
6	Bypass switch	Double-throw switch is selected to ensure that the off-grid load port can be continuously powered during inverter maintenance
7	Smart meter	Shipped with Inverter



Watch out:

Recommended switch and circuit breaker specifications are as follows:

Model	Battery circuit breaker		AC circuit breaker	
	Voltage voltage (Vdc)	Current of electricity (A)	Voltage voltage (Vdc)	Current of electricity (A)
ASG-3.6SL-ZH	≥ 480	40	≥ 230	21
ASG-4SL-ZH	≥ 480	40	≥ 230	23
ASG-4.6SL-ZH	≥ 480	40	≥ 230	27
ASG-5SL-ZH	≥ 480	40	≥ 230	30
ASG-6SL-ZH	≥ 480	40	≥ 230	35

4.2 Application mode

4.2.1 Self-Use



Watch out:

It is applicable to regions with high electricity cost, low electricity sales revenue and stable power grid.

PV energy adequacy:

PV energy shall be used to supply power to the load in priority, excess energy shall be used to charge the battery, and the remaining energy shall be sold. As shown in the figure below, 1、2、3 represents energy priority.

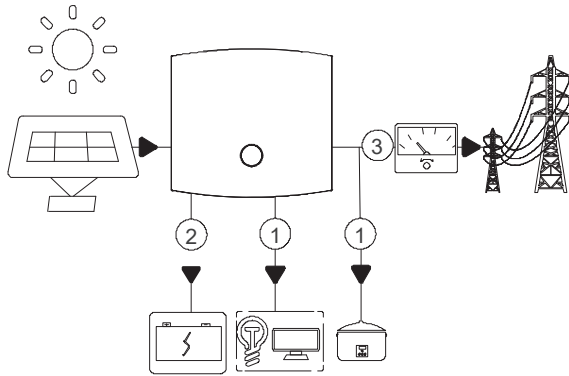

Insufficient PV energy or night conditions:

The load energy is preferentially supplied by the PV energy, supplemented by the battery discharge. If the battery energy is insufficient, the power is purchased from the grid.

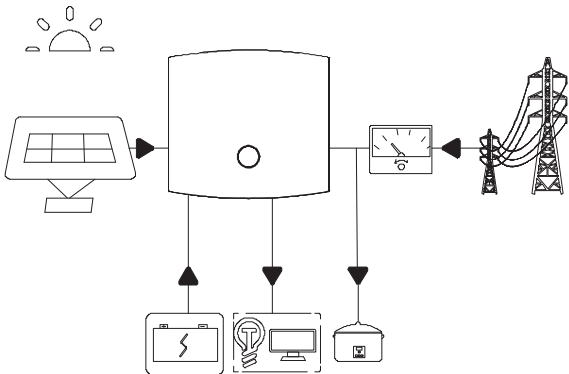

4.2.2 UPS mode



Watch out:

- It is applicable to areas with important load and unstable power grid.
- All energy priorities are to ensure that the battery reserves energy as much as possible to ensure that off-grid output loads can be powered in case of grid abnormality.

Day time:

The PV energy shall be used to charge the battery in priority, the excess energy shall be used by the load, and the remaining energy shall be sold. As shown in the figure below, 1. 2. 3 represents energy priority.

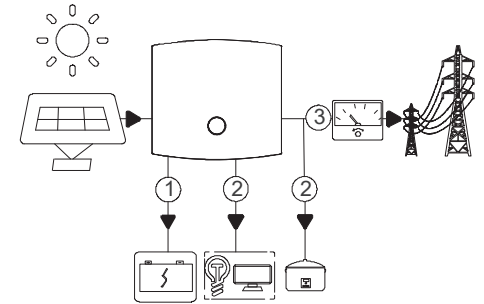

Night time

The power grid is normal, the power is purchased from the power grid to supply power for the load, and the battery is used for power protection.

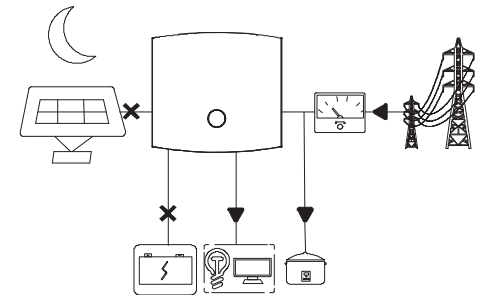

Night time

The grid is abnormal, the inverter enters the off-grid mode, and the battery discharges to supply power to the off-grid port load.

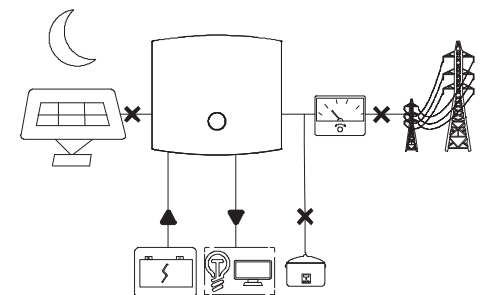

4.2.3 peak load shifting



Watch out:

- The economic mode can only be selected if the local laws and regulations are met. For example, if the power grid is prohibited to charge the battery, do not use this mode.
- It is recommended to use peak shaving and valley filling in the scenario with large difference between peak and valley electricity prices.

Grid peak period:

Set the PV energy priority as load → grid → battery within the time range of 04:01~23:59. PV energy will flow preferentially to off-grid load, and excess energy will be sold.

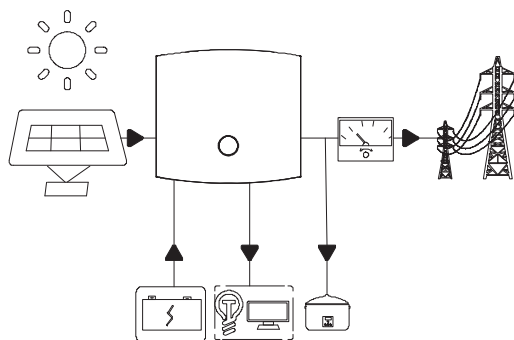

Grid valley period:

Set the charging time of the grid as 00:00~04:00, and purchase electricity from the grid to charge the battery.

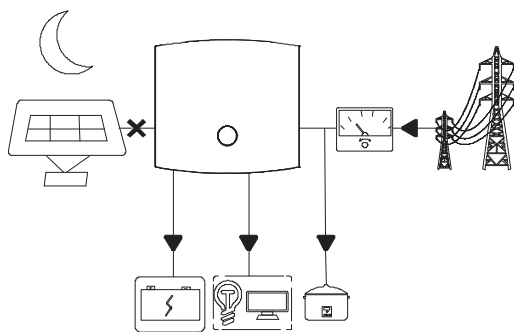

4.3 Function characteristics

4.3.1 Power derating

In order to make the inverter operate safely, the inverter will automatically reduce the output power when the operating environment is not ideal.

The following factors may cause power derating, so please try to avoid them during use.

- Unfavorable environmental conditions such as direct sunlight, high temperatures, etc
- The inverter's output power percentage has been limited by the app or web-end settings
- Variation with grid voltage frequency
- High input voltage
- High input current value
- Insufficient battery pack power configuration

4.3.2 Battery Standby Active Shutdown

In order to protect the battery SOC, when only the battery is powered and in the standby mode, the inverter will automatically turn off the power supply and enter the power saving mode. At this time, the battery discharge power is 0W, and the remote communication and other functions are synchronously stopped. After the mains supply is recovered or the PV is recovered, the inverter will be automatically activated again.

If the battery is required to supply power separately and start the inverter power supply due to application or commissioning, please turn on the battery switch and activate the battery, then press the cold start button under the machine for 5 seconds, wait for a moment, the panel lamp will be on, at this time, the machine can be started off the network and set.

5 INSTALLATION

5.1 Installation Requirements

5.1.1 Environmental requirements

- The protection class of inverter is IP66, which can be installed indoor and outdoor.
- Equipment shall not be installed in flammable, explosive and corrosive environment.
- The installation position shall be kept away from the accessible range of children and the position easy to be touched. High temperatures may be present on the surface when the equipment is in operation to prevent burns.
- The installation position shall avoid the water pipe and cable in the wall to avoid danger during punching.
- The inverter shall avoid salt damage areas and installation environments such as sunshine, rain and snow. It is recommended to install the inverter in a sheltered installation position. If necessary, a sunshade can be erected.
- When installing the inverter, certain space shall be reserved around the inverter to ensure sufficient installation and heat dissipation space.
- Under the installation scenario of multiple inverters, when the space is sufficient, the installation mode of "straight line" is recommended; When the space is insufficient, it is recommended to install the product in a zig-zag manner. It is not recommended to install multiple inverters by overlapping.
- The installation height of the equipment shall be convenient for operation and maintenance, ensure that the equipment indicator lights, all labels are easy to see, and the terminal blocks are easy to operate.
- The inverter is installed at an altitude lower than the maximum working altitude of 4000m.
- Keep away from strong magnetic field environment to avoid electromagnetic interference. If there is a radio station near the installation location or wireless communication equipment below 30MHz, please install the equipment according to the following requirements:

Ferrite core with multi-circle winding or low-pass EMI filter at inverter DC input or AC output.

The distance between inverter and wireless electromagnetic interference equipment exceeds 30m.

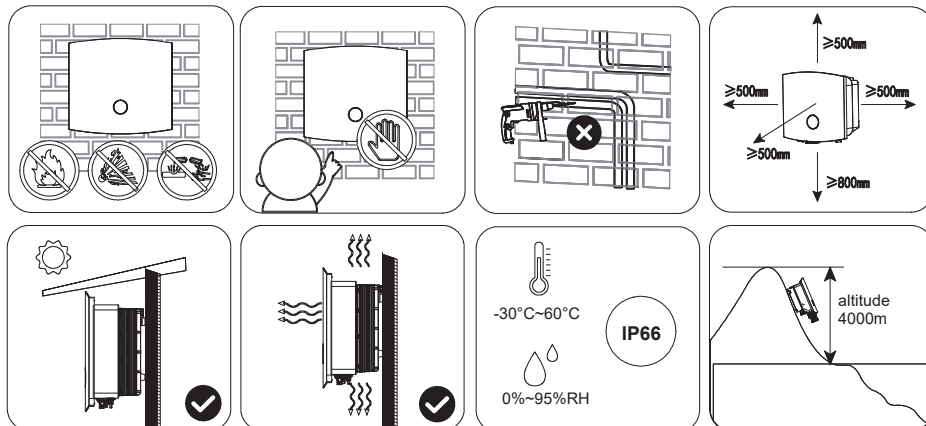

5.1.2 Carrier Requirements

- Installation carriers must not be flammable and must be fire resistant.
- Please make sure that the mounting carrier is solid and reliable and can bear the weight of inverter. The equipment will vibrate during operation, so do not install it on the carrier with poor sound insulation, so as to avoid disturbance to residents in the living area caused by the noise generated by the equipment during operation.

5.1.3 Installation angle requirements

- Recommended inverter installation angle: vertical or pitching $\leq 15^\circ$.
- Do not invert, tilt forward, tilt backward beyond the angle and install the inverter horizontally.

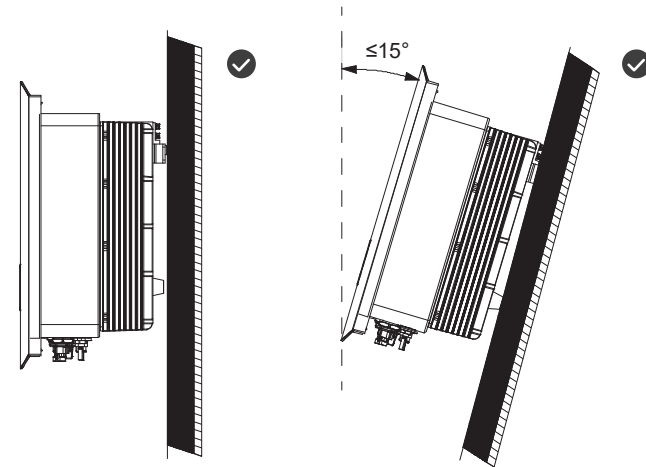

5.1.4 Installation tool requirements

The following installation tools are recommended for installation. Other auxiliary tools can be used on site if necessary.



5.2 Installation of inverter

5.2.1 Handling inverter



Watch out:

- Transportation, turnover, installation and other operations must meet the requirements of national and regional laws and regulations and relevant standards.
- Please equip corresponding personnel according to the weight of the equipment to prevent the equipment from exceeding the weight range that can be handled by human body and damaging personnel.
- Wear safety gloves to avoid injury.
- Please make sure that the equipment is balanced during handling to avoid dropping.

5.2.2 Installation of inverter



Watch out:

- When drilling holes, make sure that the drilling position is kept away from water pipes, cables, etc. in the wall to avoid danger.
- Wear goggles and dust mask when punching to avoid dust inhalation into respiratory tract or into eyes.
- Make sure that the inverter is securely installed to prevent injuries from falling.

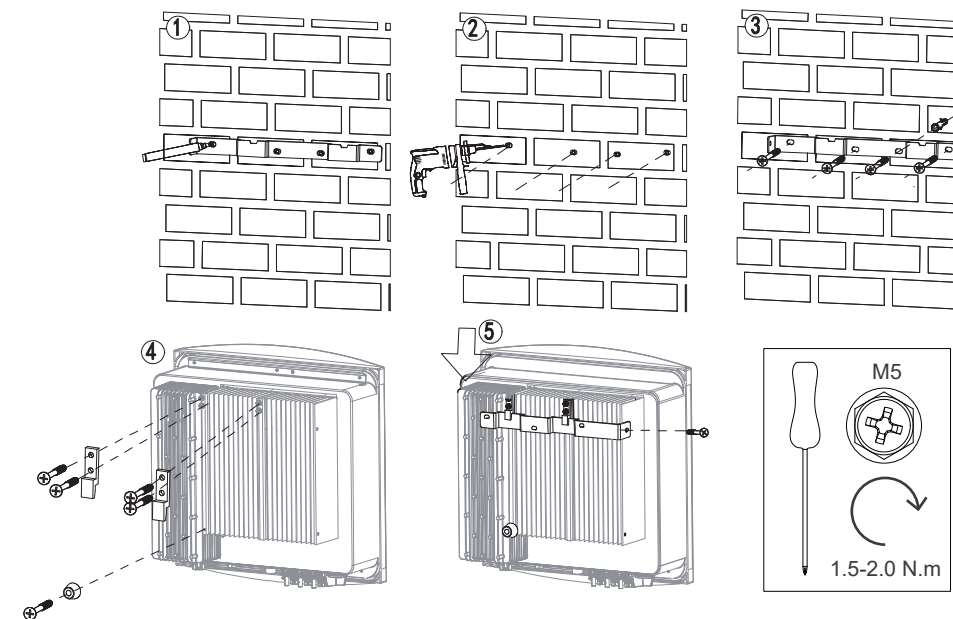

5.3 Electrical connection

5.3.1 Safety precautions



Danger:

- Specifications of all operation, cables and components used in electrical connection shall comply with local laws and regulations.
- Before electrical connection, please disconnect the DC switch and AC output switch of inverter to make sure that the equipment is powered off. It is strictly forbidden to operate with electricity, otherwise, electric shock and other hazards may occur.
- Cables of the same type shall be bound together and arranged separately from cables of different types. It is forbidden to wind or cross cables.
- If the cable bears too much tension, it may lead to poor wiring. When wiring, please reserve a certain length of the cable before connecting to the inverter wiring port.
- When crimping the connecting terminal, please make sure that the conductor part of the cable is fully contacted with the connecting terminal, and do not crimp the cable insulation skin together with the connecting terminal; otherwise, the equipment may be unable to operate, or the inverter terminal block may be damaged due to heating due to unreliable connection after operation.



Watch out:

- When making electrical connection, please wear safety shoes, protective gloves, insulating gloves and other personal protective equipment as required.
- Only professionals are allowed to carry out operations related to electrical connection.

5.3.2 Connecting protective earth wire

Warning:

- The protective grounding of the crate shell cannot replace the protective grounding wire of the AC output port. When wiring, ensure that the protective grounding wires at the two places are reliably connected.
- In case of multiple inverters, make sure that the protective earthing point of all inverter crate enclosures is equipotentially connected.
- To improve the corrosion resistance of the terminal, it is recommended to apply silicone or paint on the external of the grounding terminal for protection after the connection and installation of the protective ground wire.
- Please prepare the protective ground wire, and the recommended specification:
Type: Outdoor single-core copper wire
conductor cross-section: 4-6mm² (12 - 10AWG)

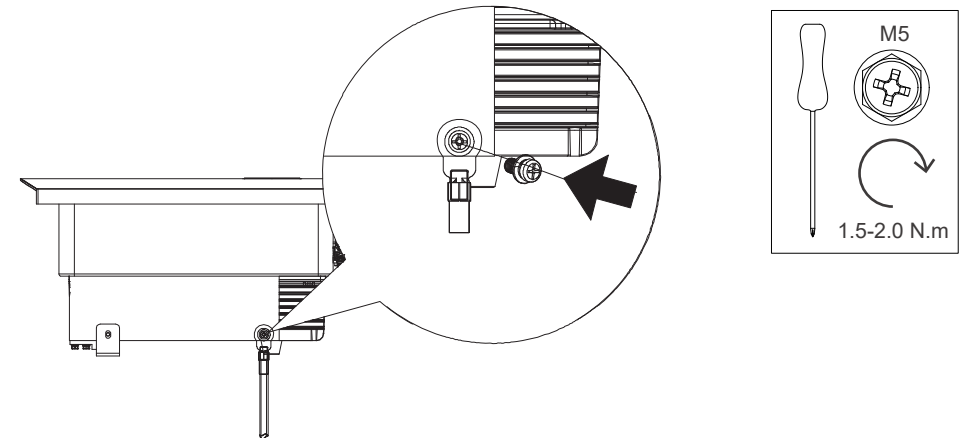
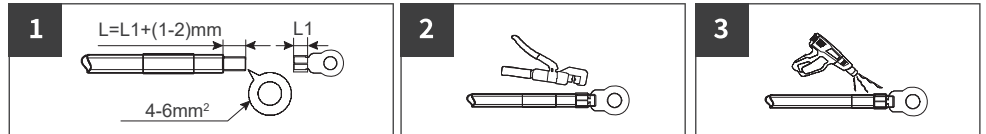

5.3.3 Connect PV input line

Danger:

- Do not connect the same PV string to multiple inverters, or the inverter may be damaged.
- Please make sure that the maximum short circuit current and maximum input voltage of each MPPT are within the allowable range of the inverter.
- Please make sure that the positive electrode of the PV string is connected to the PV port+ of the inverter, and the negative electrode of the PV string is connected to the PV port - of the inverter.
- Please prepare your own PV input line. Recommended specification:
 Type: Outdoor PV multi-core copper wire
 conductor cross-section: 4-6mm² (12 - 10AWG)
 Outer diameter of conductor insulation layer: φ3~7mm



Warning:

- PV string output does not support grounding. Before connecting PV string to inverter, please make sure that the minimum insulation resistance to ground of PV string meets the minimum insulation impedance requirements ($R = \text{maximum input voltage} / 30\text{mA}$).
- Make sure that the DC cables are firmly connected without looseness after connection.
- Use a multimeter to measure the positive and negative electrodes of the DC cable and ensure that the positive and negative electrodes are correct without reverse connection; and the voltage is within the allowable range.

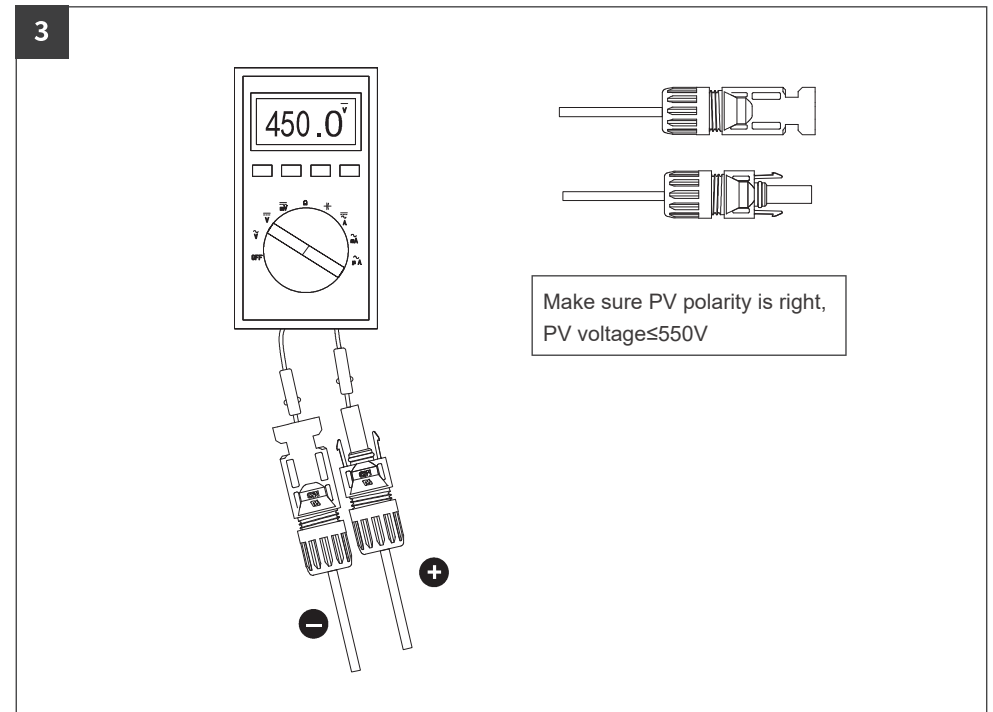
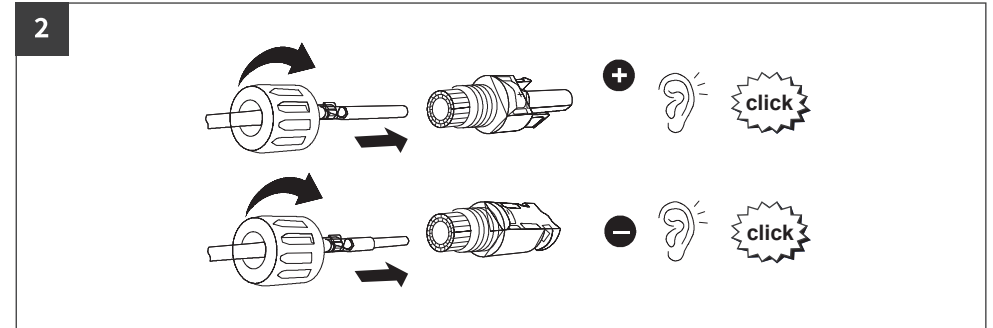
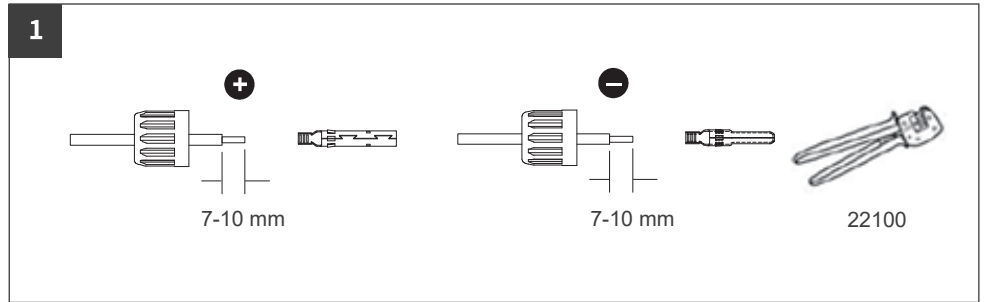
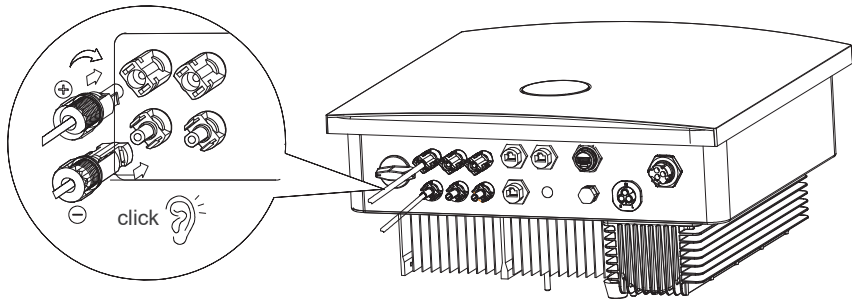

5.3.4 Connect the battery input line

Danger:

- The inverter manufacturer shall approve the battery used with inverter, and the approved battery list can be obtained through the official website.
- Short-circuit of battery may cause personal injury. Instantaneous large current caused by short circuit can release a lot of energy and may cause fire.
- Before connecting the battery line, please confirm that the inverter and battery are powered off and the front and rear switches of the equipment are disconnected.
- When the inverter is operating, do not connect or disconnect the battery cable. Violation operation may cause electric shock.
- When connecting the battery line, please use insulated tools to prevent accidental electric shock or battery short circuit.
- Make sure that the battery open circuit voltage is within the allowable range of the inverter.
- One DC switch is required between inverter and battery.
- Please prepare your own PV input line. Recommended specification:
 - Type: Outdoor PV multi-core copper wire
 - Conductor sectional area: 8mm² (8AWG)
 - Outer diameter of conductor insulation layer: φ3~7mm



Warning:

- During wiring, the battery line is completely matched with the "BAT+", "BAT -" and grounding port of the battery terminal. If the cable connection is wrong, the equipment will be damaged. Do not connect load between inverter and battery.
- Do not connect the same battery pack to multiple inverters as this may cause inverter damage.
- Make sure that the DC cables are firmly connected without looseness after connection. Use a multimeter to measure the positive and negative electrodes of the DC cable and ensure that the positive and negative electrodes are correct without reverse connection; and the voltage is within the allowable range.

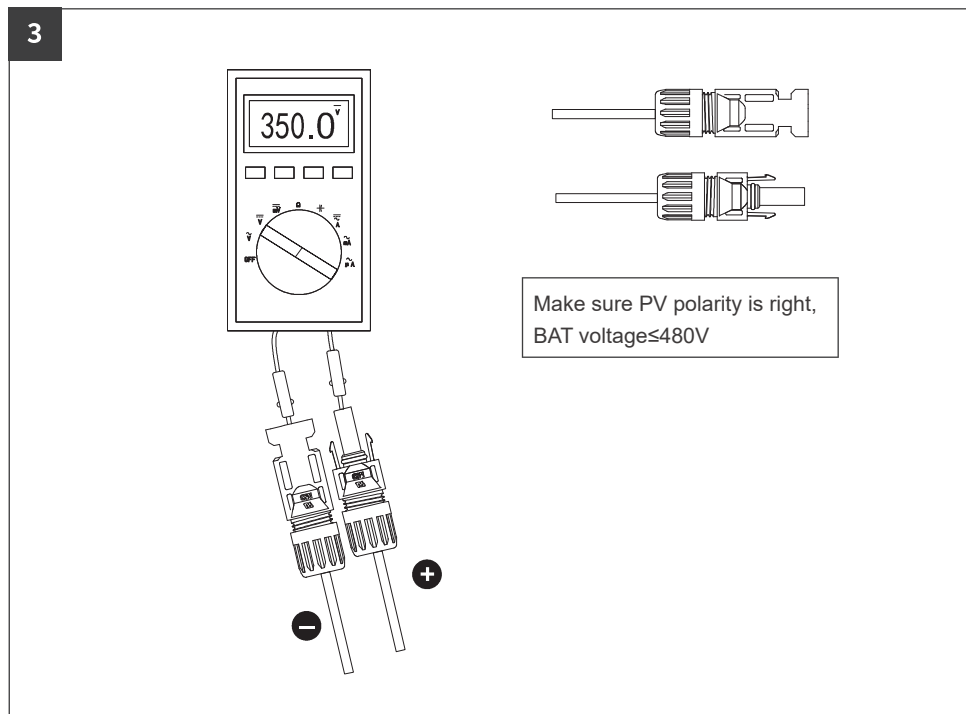
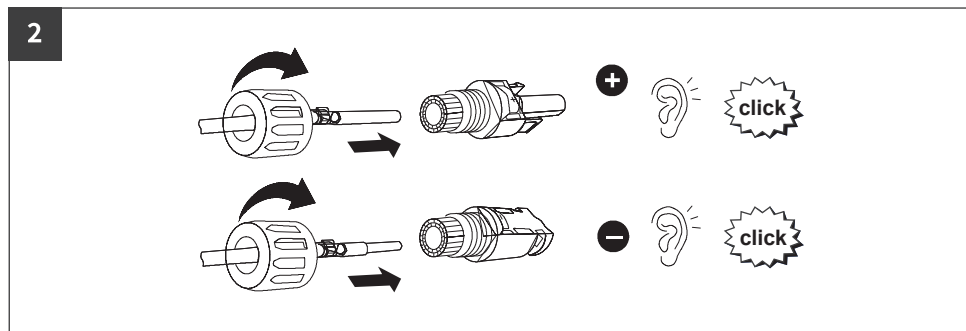
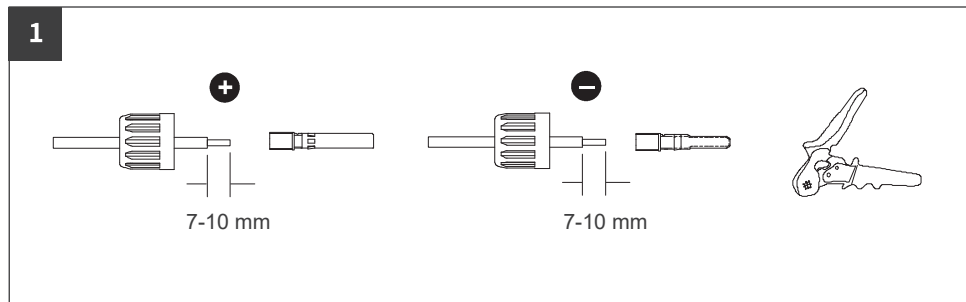
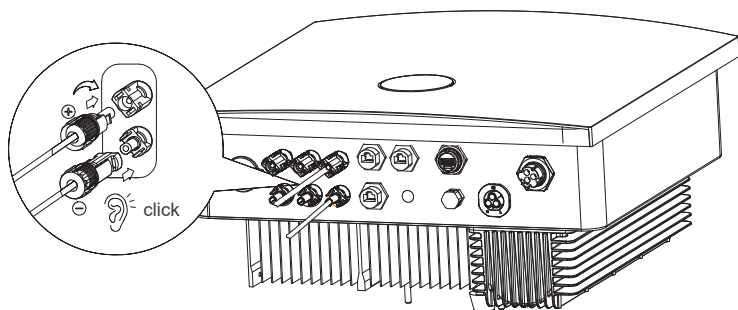

5.3.5 Connecting AC line

Danger:

- In order to ensure that the inverter and the grid can be safely disconnected from the grid in case of abnormal conditions, please connect the AC switch on the AC side of the inverter. Multiple inverters cannot be connected to one AC switch at the same time. Please select proper AC switch according to local regulations.
- When the inverter is powered on, the AC off-grid port will be charged. If the off-grid port load needs to be maintained, make sure to disconnect the off-grid port circuit breaker or power down the inverter, otherwise it may cause electric shock.
- Please prepare your own PV input line. Recommended specification:
 - Type: Outdoor AC single-core copper wire
 - Conductor sectional area: 6mm² (10AWG)
 - Outer diameter of conductor insulation layer: φ13~18mm
- If multi-core copper wire is selected, supporting crimping terminal shall be used for assembly. It is forbidden to directly press multi-core copper wire into the connector.



Warning:

- The residual current monitoring unit (RCMU) is integrated inside the inverter, and when the inverter detects a leakage current greater than the allowable value, it will quickly disconnect from the power grid.
- When wiring, the AC line matches the "L", "N", and grounding ports of the AC terminal completely. If the cable is connected incorrectly, it will cause equipment damage.
- Please make sure that the wire core is fully inserted into the terminal-wiring hole and not exposed.
- Make sure that the cable connections are tight, otherwise equipment operation may cause overheating of the wiring terminals and damage to the equipment
- When connecting AC cables, it is recommended to first connect the off grid cable and then connect the mains cable. It is strictly prohibited to connect the mains cable to the off grid output port.

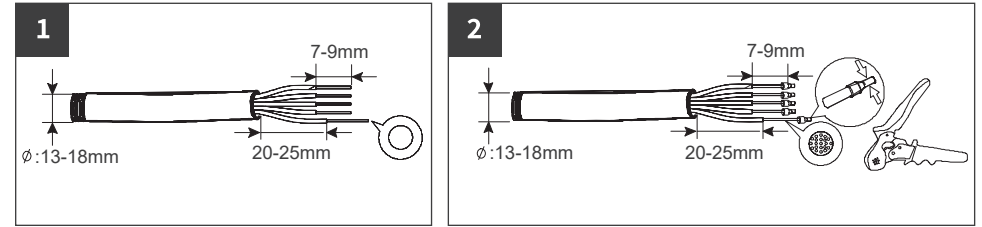
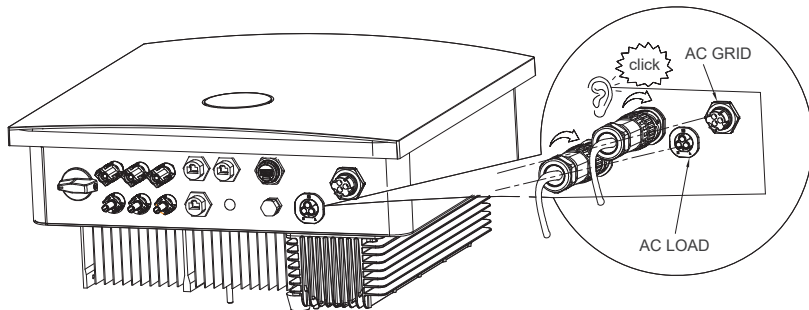

Explanation:

1. It is a single core wire and does not require terminal pressing operation;
2. For multi-core wires, cold pressing terminal crimping pliers are required to press the terminals.

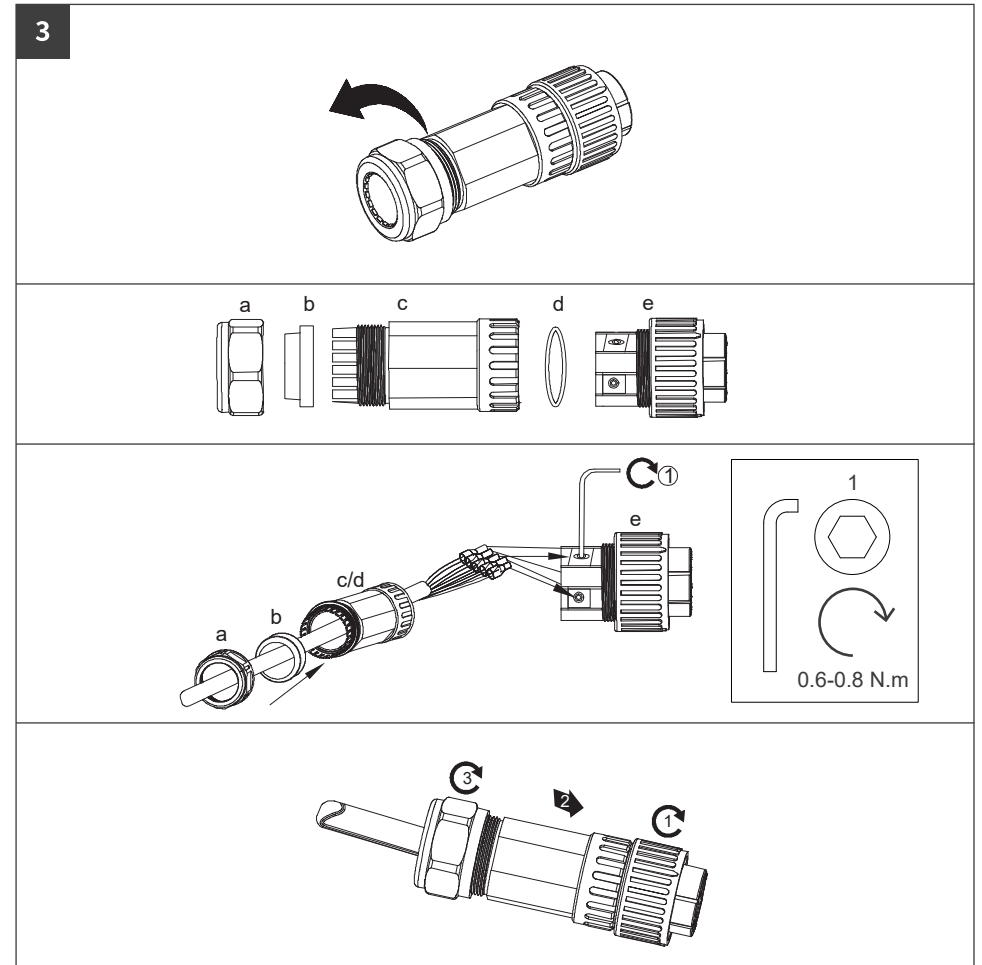

5.3.6 Smart meter (optional)

Watch out:

- When connecting communication lines, please ensure that the definition of the wiring port matches the device perfectly, and the cable routing should avoid interference sources, power lines, etc. to avoid affecting signal reception.
- The electrical meter and CT are shipped with the inverter, and the relevant parameters have been preset at the factory. Please do not modify the relevant parameters of the electricity meter and CT.
- Each inverter needs to be connected to a separate meter. Do not connect multiple inverters to the same electrical meter.
- To ensure the normal use of the electricity meter and CT, please ensure the following: Please ensure that the CT is matched and connected to the phase line, and the CT is connected to the L-line.
- Please connect the CT according to the direction of the meter. If it is reversed, a CT reverse fault will be reported.
- The length of the CT cable provided with the inverter is 3m or 5m. Please install the electricity meter and CT according to the actual situation.
- Please provide your own communication cable for the electrical meter, and it is recommended to use T568B standard network cables of Class 5 or higher standards.
- The communication line connecting the electrical meter to the inverter supports a maximum of 100m and can be connected to a standard RJ45 crystal head. The port definition is as follows:

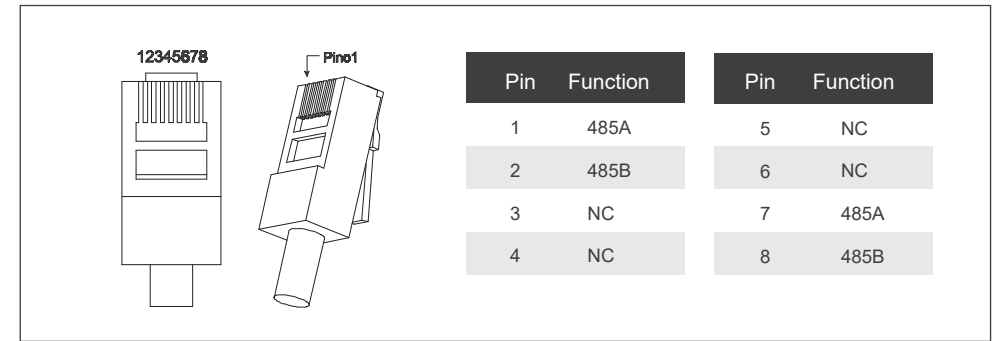
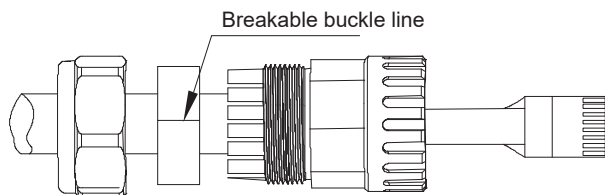
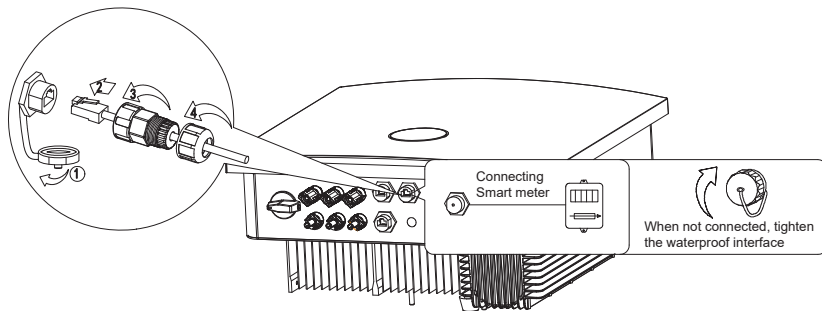

ASG single-phase inverter can meet the requirements of retail electricity function through a smart meter and CT

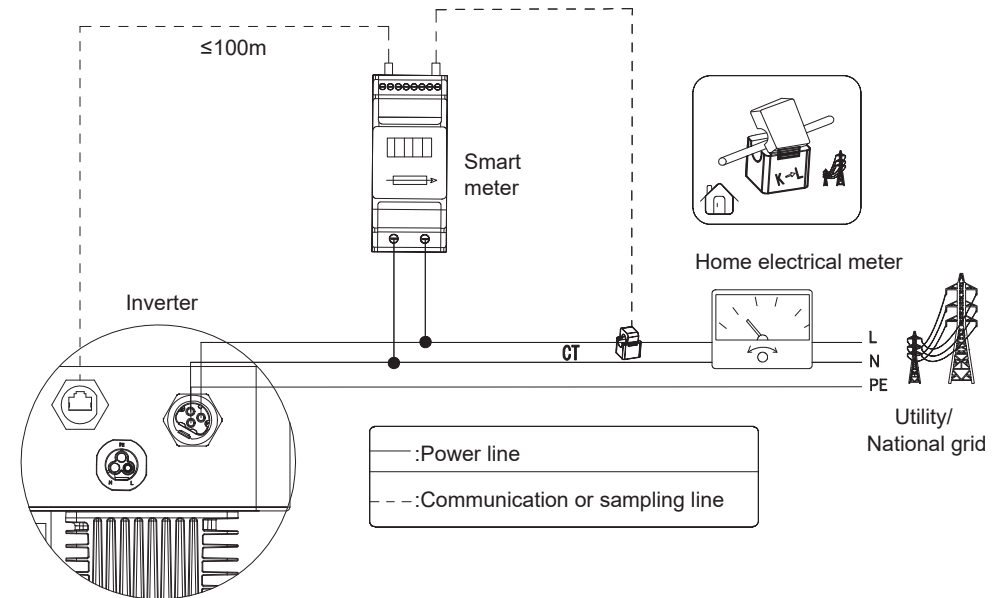

5.3.7 BMS communication

Watch out:

- When connecting the communication line, please ensure that the wiring port definition is completely matched with the equipment, and the cable route shall avoid the interference source, power line, etc. to avoid affecting the signal receiving. CAN communication or RS485 communication shall be selected between inverter and battery according to actual demand. Please prepare the BMS communication line by yourself. It is recommended to use the Cat5e and above standard network cable of T568B standard. It is suggested that the communication line between BMS and inverter should be ≤ 5 m, and standard RJ45 crystal head can be connected. The port definition is as follows:

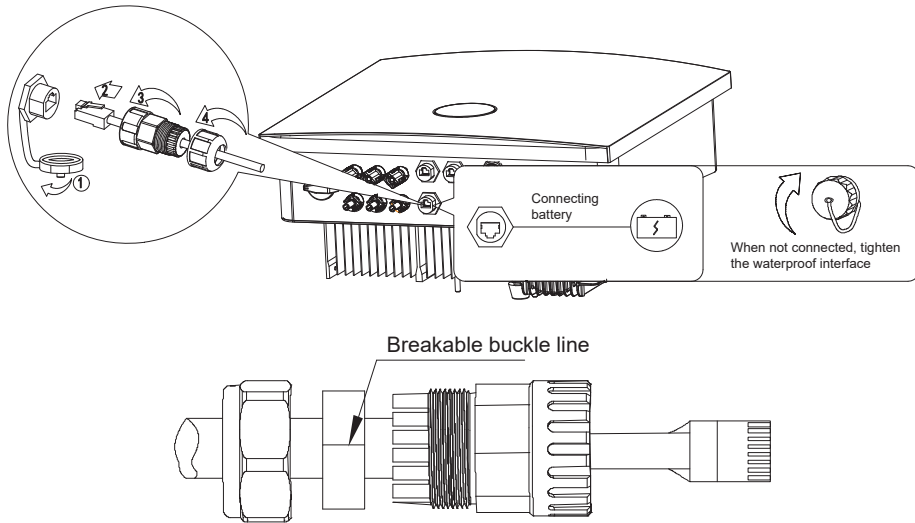

Pin	Function	Pin	Function
1	NC	5	CANL
2	NC	6	GND
3	NC	7	485A
4	CANH	8	485B

5.3.8 DRM Control (optional)

Watch out:

- When connecting the communication line, please ensure that the wiring port definition is completely matched with the equipment, and the cable route shall avoid the interference source, power line, etc. to avoid affecting the signal receiving. Please prepare the meter communication line by yourself. It is recommended to use the Cat-5 and above standard network cable of T568B standard. The communication line between DRM and inverter can be connected with standard RJ45 crystal head, and the port definition is as follows:

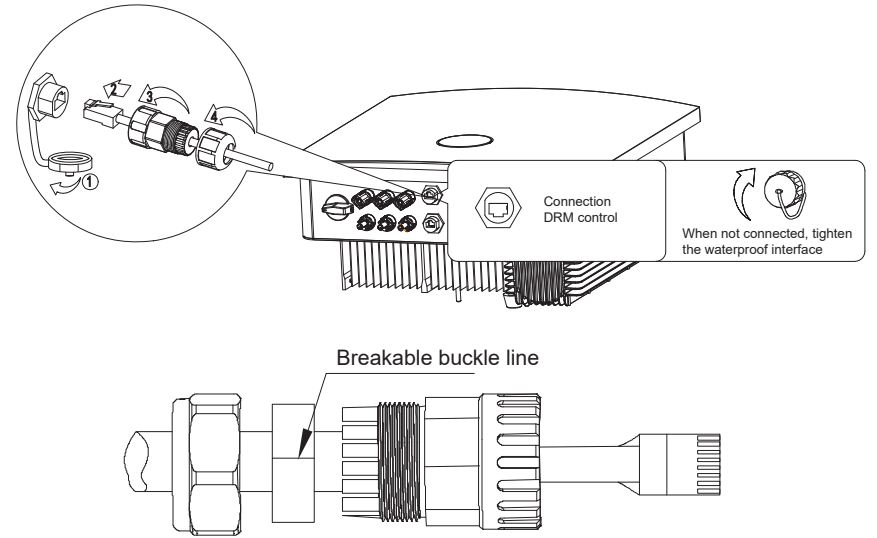

Pin	Function	Pin	Function
1	DRM 1/5	5	REF
2	DRM 2/6	6	GND
3	DRM 3/7	7	+12V
4	DRM 4/8	8	GND

5.3.9 Datalogger Connection (Optional)



Watch out:

Detailed introduction of communication module can be obtained from the official website.

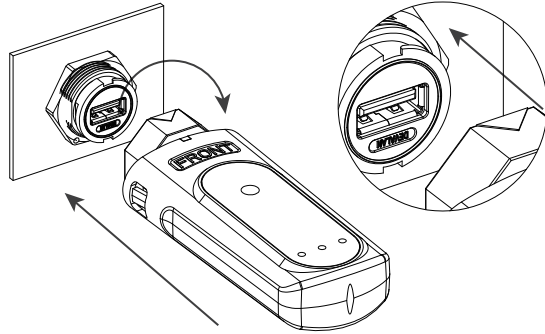

6 EQUIPMENT COMMISSIONING AND MAINTENANCE

6.1 Check before power-on

Items	Checking items	Standard
1	Installation of inverter	The inverter shall be installed correctly, firmly and reliably
2	Cable arrangement	Cables shall be reasonably arranged and well protected, without damage
3	Datalogger	The data logger shall be installed correctly, firmly and reliably
4	Identifying	The safety signs and warning labels on the inverter are not blocked or damaged
5	Switch	DC SWITCH "and all switches connected to the inverter are" OFF "
6	Cable connection	The AC output line, DC input line and grounding wire are connected correctly, firmly and reliably
7	Unused terminals and interfaces	Unused terminals and interfaces are protected with waterproof covers
8	Circuit breaker	Reasonable selection of AC and DC circuit breakers
9	Environmental requirements	Reasonable installation space, clean and tidy environment, no construction remains

6.2 Power on the equipment

- Step 1: At the AC switch between the inverter and the power grid, measure the voltage at the power grid side with a multi-meter, and confirm that the power grid voltage is at the working power of the inverter Allowable pressure range.
- Step 2: Close the AC switch between inverter and utility/national grid.
- Step 3: Close the DC switch between inverter and battery.
- Step 4: Set "DC SWITCH" on the inverter to "ON".
- Step 5: Observe the inverter LED indicator and check the inverter operation status.

6.3 Set inverter parameters via App



Watch out:

To ensure that the inverter works properly, please use the AUXSOL application program to complete the inverter parameter setting.

Scan the QR code below to download the AUXSOL application or log in <https://www.auxsolcloud.com> Download this application.



Watch out:

Please also obtain the operating instructions of the communication rod from the official website, to set the contents more consistent with the application scenario.

6.4 Power off the equipment



Danger:

- When operating and maintaining the inverter, please turn off the inverter for treatment. Live operation of the equipment may cause damage to the inverter or electric shock.
- After the inverter is powered off, it will take a certain amount of time for internal components to discharge. Please wait until the equipment is fully discharged according to the required label time requirements.

- Step 1: Disconnect the AC switch between the inverter and the utility/ national grid.
- Step 2: At the AC switch between the inverter and the utility/ national grid, measure the voltage on the power grid side with a multi-meter to confirm that the power has been cut off.
- Step 3: Disconnect the DC switch between inverter and battery.
- Step 4: Observe the inverter LED indicator, check the inverter operation status, and confirm to enter standby.
- Step 5: Set "DC SWITCH" on inverter to "OFF".

6.5 Equipment removal



Danger:

- Make sure inverter is power off.
- Wear personal protective equipment when operating the inverter.

Step 1: successively remove all electrical connections of inverter, including DC line, AC line, communication line, communication module and protective earth wire.

Step 2: Remove the inverter from the back cladding.

Step 3: Remove the back cladding.

Step 4: Properly save the inverter and ensure that the storage conditions meet the requirements if the subsequent inverter is still put into use.

6.6 Equipment scrapping

If the inverter cannot be used anymore and needs to be scrapped, please dispose according to the electrical waste disposal requirements of the inverter country/region.

The inverter shall not be treated as household garbage.

6.7 Fault Handling

Please troubleshoot according to the following methods. If the troubleshooting methods cannot help you, please contact the after-sales service center.

When contacting the after-sales service center, please collect the following information for quick solution.

1. Inverter information, such as serial number, software version, equipment installation time, fault occurrence time, fault occurrence frequency, etc.
2. Equipment installation environment, such as weather conditions, whether components are sheltered and whether there is shadow, etc. It is recommended to provide photos, videos and other documents to assist in analyzing problems.
3. Utility/National grid condition.

Defect codes	Defect name	Solutions
101	Bus over voltage	1.Restart inverter 2.If it still fails after restarting, contact the installer.
102	Bus under voltage	Off-grid mode: 1. Disconnect the off-grid load and restart the inverter. If the restart is normal, increase the battery or reduce the off-grid load; 2. If it still fails after restarting, contact the installer. On grid mode 1. Restart the inverter 2. If it still fails after restarting, contact the installer.
103	Bus unbalance	1. Restart inverter 2. If it still fails after restarting, contact the installer.
104	Bus over voltage	
201	Battery soft start timeout	
202	Utility/national grid supply soft start timeout	
203	Soft start timeout	1. Restart inverter 2. If it still fails after restarting, contact the installer.
301	Inverter soft start timeout	
401	DCDC over current	Disconnect the battery, check whether the battery output and inverter battery terminal are short-circuited, and restart the inverter after no short circuit; If the fault still exists after restarting, contact the installer.
501	DCDC over current	
601	Inverter overcurrent	1. Check whether the voltage and frequency of the power grid are stable. If the power grid fluctuates greatly, enable the weak current network mode and then restart the inverter; 2. If the fault still exists after restarting, contact the installer.
701	Inverter overcurrent	

Defect codes	Defect name	Solutions
801	Inverter high voltage	<ol style="list-style-type: none"> 1. Restart inverter 2. If it still fails after restarting, contact the installer.
901	Inverter low voltage	<ol style="list-style-type: none"> 1. Disconnect the off-grid load and restart the inverter. If the restart is normal, increase the battery or reduce the off-grid load; 2. If the fault still exists after restarting, contact the installer.
1001	Battery high voltage	<ol style="list-style-type: none"> 1. Confirm whether the inverter charging voltage setting matches the battery specification; 2. If the setting is normal and still appears, please contact the installer.
1101	Reverse connection of battery	Disconnect inverter PV/national grid (utility) /battery input, adjust battery positive and negative wiring after inverter shutdown, and then restart inverter.
1201	Off-grid output overload	Reduce off-grid output measurement load of inverter.
1301	Off-grid output short circuit	Disconnect the inverter PV/grid/battery input and check the corresponding off-grid output test wiring and load short circuit.
1401	Off-grid load reverse flow	Increase the power absorption device at the off-grid output of inverter.
1501	Excessive temperature in the box	<ol style="list-style-type: none"> 1. The inverter shall be wall-mounted in the environment where the ambient temperature does not exceed 60°C; 2. If the installation method and environment are normal, please contact the installer.
1502	Battery module over temperature	
1503	PV module over temperature	
1504	Over-temperature of inverter module	

Defect codes	Defect name	Solutions
1601	DC current out of limits	<ol style="list-style-type: none"> 1. Restart inverter 2. If it still fails after restarting, contact the installer.
1801	PV1 input overvoltage	Check solar panel configuration to ensure open circuit voltage is less than 1000V.
1802	PV2 input overvoltage	
1901	PV input overcurrent	<ol style="list-style-type: none"> 1. Restart inverter 2. If it still fails after restarting, contact the installer.
2001	PV input overcurrent	
2101	PV input arc protection	Disconnect the inverter PV/battery/national grid (utility) input, and check whether the wiring from the solar panel to the inverter input terminal is damaged/in poor contact.
2201	PV1 input reversal connection	Disconnect inverter PV/battery/national grid(utility) input, exchange positive, and negative pole connections of PV1.
2202	Reverse connection of PV2 input	Disconnect inverter PV/battery/national grid(utility) input, exchange positive, and negative pole connections of PV2.
2301	Short circuit of PV1 input	Contact the installer.
2302	PV2 input short circuit	
2401	Internal fan failure	
2901	ISO defects	<ol style="list-style-type: none"> 1. Confirm whether the insulation of PV input wiring is normal; 2. Wait for the inverter to automatically recover, otherwise contact the installer.
3001	GFCI sensor fault	<ol style="list-style-type: none"> 1. Restart inverter 2. If it still fails after restarting, contact the installer.
3002	GFCI Exceeding the standard	<ol style="list-style-type: none"> 1. Confirm whether the insulation of PV/grid input wiring is normal; 2. Contact the installer.

Defect codes	Defect name	Solutions
3101	Auxiliary source anomaly	Contact the installer.
3202	Control panel wiring abnormality	
3303	Relay failure	1. Restart inverter 2. If it still fails after restarting, contact the installer.
3401	Excessive zero deviation of inverter current sampling	1. Restart inverter 2. If it still fails after restarting, contact the installer.
3501	Excessive zero deviation of output current sampling	
3601	Excessive zero deviation of DC current sampling	
3701	PV1 Excessive zero deviation of current sampling	
3702	PV2 Excessive zero deviation of current sampling	
3801	GFCI Excessive sampling zero deviation	
3901	Excessive zero deviation of battery current sampling	
4201	DRM Shutdown	Respond to scheduling shutdown without handling.
4301	DSP&ARM version mismatch	Contact the installer.
4302	Incompatible hardware version	
4503	Memory exception	

6.8 Regular maintenance



Danger:

The machine must be kept power off state during maintenance.



Watch out:

Regular maintenance can maintain the stability of inverter performance.

Content	Method	Cycle
System Cleaning	Check the cooling fin and air inlet/outlet for foreign matter and dust. Especially the fan needs regular maintenance to prevent debris from blocking the fan and affecting the operation of the inverter	half year
DC switch	Turn on and off the DC switch for 10 times continuously to ensure the normal function of DC switch.	one year
Electrical connection	Check whether the electrical connection is loose, whether the cable appearance is damaged and whether there is copper leakage.	half year
Tightness	Check whether the tightness of the equipment inlet hole meets the requirements. If the gap is too large or not sealed, it shall be re-closed.	one year

7 TECHNICAL PARAMETER

Model	ASG-3.6SL-ZH	ASG-4SL-ZH	ASG-4.6SL-ZH	ASG-5SL-ZH	ASG-6SL-ZH
Input DC					
Max.input voltage	550V				
Rated voltage	360V				
MPPT voltage range	90-520V				
Max.input current	16A/16A				
Max.short circuit current	20A/20A				
MPPT number	2				
Max. input strings number	2				
Maximum input power of a single MPPT	3.6kW	4kW	4kW	5kW	5kW
Battery					
Battery type	Li-ion				
Rated battery voltage	350V				
Battery voltage range	80V-480V				
Max. charge / discharge current	30A/30A				
Communication	CAN/RS485				
Charging strategy for Li-Ion battery	Self-adaption to BMS				

Output AC (Grid side)					
Rated output power	3.6kW	4kW	4.6kW	5kW	6kW
Max. apparent output power	3.96kVA	4.4kVA	4.96kVA	5.5kVA	6.6kVA
Rated grid voltage	220 V / 230 V				
Rated grid frequency	50Hz/60Hz				
Max. output current	17.2A	19.1A	22A	23.9A	28.7A
Power Factor	>0.99 (0.8 leading - 0.8 lagging)				
THDi	<3%				
Input AC (Grid side)					
Max. input power	4.8kW	5.3kW	6.2kW	6.7kW	8kW
Max. input current	21A	23A	26.8A	29.1A	34.8A
Rated input voltage	1/N/PE, 220 V / 230 V				
Rated input frequency	50Hz/60Hz				
Output AC (Back-up)					
Rated output power	3.6kW	4kW	4.6kW	5kW	6kW
Max. apparent output power	4.3kVA	4.8kVA	5.5kVA	6kVA	6.6kVA
Max. output current	15.6A	17.4A	20A	21.7A	26A
Back-up switch time	< 10ms				
Rated output voltage	220V/230V				
Rated frequency	50 Hz / 60 Hz				
THDv	<2%				

Efficiency	
Max. efficiency	98.10%
EU efficiency	97.30%
BAT charged by PV Max. efficiency	98.50%
BAT charged/discharged to AC Max. efficiency	97.60%
MPPT Efficiency	99.80%
Protection	
Integrated DC switch	yes
DC rever-polarity protection	yes
Anti-islanding protection	yes
Short circuit protection	yes
Output over current protection	yes
DC Surge protection	Type II
AC Surge protection	Type II
Insulation impedance detection	yes
Ground fault monitoring	yes
Residual leakage current detection	yes
Temperature protection	yes
Battery reverse protection	yes
AC Over voltage protection	yes
DC Over current protection	yes
I/V Curve scanning	Optional
24-hour load monitoring	Optional
Integrated AFCI (DC arc-fault circuit protection)	Optional
Antibackflow	Optional
LVRT	Optional

General Data	
Dimensions (W*H*D)	455 x 462 x 214mm
Weight	19kg
Self consumption(night)	≤13W
Operating temperature range	-30...+60 C
Cooling concept	Natural Cooling
Max. operation altitude	4000m (Derating above 3000m)
Relative humidity	0-100%
Ingress protection	IP66
Topology structure	Transformerless
Grid connection standard	EN 50549, EN 62116, EN 61727, RD647, RD413, RD1699, UNE 217001/2, NTS631
Safety/EMC standard	IEC 62109-1 IEC 62109-2, EN IEC 62477-1, IEC 61000-6-1, IEC 61000-6-2, IEC 61000-6-3, IEC 61000-6-4, IEC 61000-3-11, EN 61000-3-12, EN 62920
Type of DC terminal	MC4 connector
Type of AC terminal	Quick connection plug
Display&Communication	
Display	LED+Bluetooth+APP
Communication interface	RS485, Optional: WIFI, 4G